

# Sutron Voice Modem Operation Manual

Models: 8080-0005-1 and -2

## TABLE OF CONTENTS

Overview .....	1
Jumpers and Connections .....	2
Recommended Jumper Settings.....	2
Operation with the Xpert/Xlite .....	3
Operation with Xpert- NIFC option (-2 model) .....	5
Connection to BK Radio.....	5
Operation with a PC.....	5
Auto power on mode.....	5
Testing/troubleshooting the modem with an Xpert or XLITE .....	6
Compliance Information .....	7

## Overview

The 8080-0005-1 is a telephone modem designed for voice and data communications with Sutron's Xpert and Xlite data recorders. (The 8080-0005-2 is a special version designed to interface to a King radio and requires the Xpert/Xlite to be configured for fire weather operations).

The 8080-0005 offers the features commonly offered by standard modern modems along with some special power-saving features. These features include:

- RS232 interface, baud rate up to 115,200
- V.90, 56 kbps data receiving
- V.34, 33.6 kbps data sending and receiving
- Voice playback and record
- DTMF decode
- -40°C to +85°C extended operating temperature
- V.42, MNP 2-4 and 10-EC error correction
- V.42bis, and MNP-5 data compression
- Auto power up on ring with 60-second timer.

## Jumpers and Connections

The modem is designed with a DB9 Female DCE connection. This allows the modem to be connected directly to DTE devices such as the Xpert and Xlite using a straight cable. Jumpers allow the DTE device to provide power to the modem through pin 9 of the DB9 connector

DB-9 PIN ASSIGNMENTS	Pin	Name	Direction
	1.	CD	Out
	2.	RD	Out
	3.	TX	In
	4.	DTR	Out
	5.	GND	GND
	6.	DSR	Out
	7.	RTS	In
	8	CTS	Out
9.	RI or PWR IN (set by J5)	Out or In	

## Recommended Jumper Settings

JUMPER ▾	JUMPER POSITION	Function	FACTORY DEFAULTS	XPERT	XLITE	8210
J4 DSR	1-2	DSR=CD				X
	2-3	DSR=DSR	X	X	X	
J5 Power	1-2	DB9 pin 9	X	X	X	X
	2-3	Jack/Terminal Block				
J3 and J7 Voltage	1-2	+12V (battery)		*		X
	2-3	+5V	X	X	X	

▾ For REV B boards (board with power jack in place of terminal block):

J3 instead of J4

J4 instead of J5

J5 instead of J3 & J7

\* Use +12V setting if Xpert has old interface board that is only capable of +12V (Female DB-9 with only one jumper).

## Operation with the Xpert/Xlite

You must configure the Xpert/Xlite in order to use the modem connected to one of the serial ports. The modem can connect to any of the serial ports; however, Sutron recommends using COM3. COM2 is typically used for SATLINK and COM1 is typically used for a direct laptop connection.

From the factory, the Xpert and Xlite will be configured to supply +5V from pin 9 of COM 3 and the modem will be configured to be powered through the DB-9 @ +5V. This arrangement will make it possible to use one RS-232 cable to both power the modem and to communicate.

NOTE: Older Xperts with the 6461-1197-1 com board can ONLY supply +12V. If using an Xpert with this board, configure the modem to accept the +12V instead of the factory default +5V.

XPERT Com board jumper settings:

6461-1197-1 has DB-9 Female connector and one jumper J1. Set to POS 2-3 for +12V out

6461-1234-1 has DB-9 Male and two jumpers J1 & J2. Set J1 to 2-3 for power out/J2 to 2-3 for +5V

*Refer to the Xpert manual for more detailed instructions on the following steps.*

The following example assumes the modem will be connected to COM3.

The first thing to do is to edit the autoexec.bat file to support the modem. This is done by adding or editing the line where the "remote" program is run. Note: you create or edit the file on your PC and then use XTERM to transfer the file to the Xpert. Adding the text "voice3:115200" tells remote that there will be a Sutron modem connected to COM3 and to use a baud rate of 115200. A typical autoexec.bat appears as follows:

```
\windows\remote com1:115200 voice3:115200  
\flash disk\xpert
```

**OPTIONAL:** For advanced customization of how the modem works, create an initialization file for the modem (e.g. scom3.ini). The modem by default is initialized so that when it powers up it will not echo characters, will not provide result codes, and will ignore DTR. Remote.exe will send the contents of the init file to the modem when it starts. A typical init file for the Sutron modem is:

```
ATS0=1  
ATE0Q1&D0&W
```

*Be sure there is a CR at the end of the last line in the file or the program will ignore the line. Again, you create or edit the scomx.ini file on your PC and then use Xterm to transfer the file to the Xpert.*

*The meaning of each setting is:*

```
S0=1  answer on first ring  
E0    don't echo characters  
Q1    don't send result codes  
&D0   ignore DTR  
&W    save settings into profile.
```

In the Setup of the Xpert/Xlite, add a COMS TAG to each data point that is needed, optionally add an ALARM block in front of the COMS TAG to trigger and send alarm data. Edit COMS TAG/ALARMS with appropriate data.

Next, set up the Xpert/Xlite control panel COMS entry. Select Coms and change COM3 to VOICE.

Once the VOICE is selected for COM3, a plus sign will allow the VOICE3 to be configured.

Set answer mode, number of rings and language.

Set phone number(s), number of redials and the redial delay (for alarms)

For voice mode:

- Select/add additional voice files for specific sensors(Prefix) and units(Suffix).

- Edit the dial-out message (for alarms)

- Edit the dial-in message

Example dial-in message. Speak prefix, data, suffix and alarm status for three sensors, then to hang up.

  - SpeakPhrase Hello welcome to the Sutron xpert

  - Pause 2.0

  - SpeakTag RAIN

  - Pause 2.0

  - SpeakTag ELEVATION

  - Pause 2.0

  - SpeakTag LEVEL

  - Hangup

For data mode:

- Nothing else needs configured.

## Operation with Xpert- NIFC option (-2 model)

When using the NIFC version (-2) the modem becomes an interface between an Xpert and a BK radio. It allows an operator to remotely "wake up" an Xpert Station with a remote BK Radio with DTMF keypad. The operator enters the unique station id of interest, and then listens to a pre-programmed set of sensor values. The modem decodes the DTMF tones and provides the speech playback capabilities for the Xpert Station.

With this option, the modem DOES NOT operate as a normal phone line modem and SHOULD NOT be connected to a phone line.

The validation of the Station ID and the configuration of the sensors to read back are all handled by the Xpert application software. Refer to the Xpert Users manual (Sutron Part Number 8800-1127) for detailed set-up instructions.

The modem jumpers should be set to connect to an Xpert (see jumper table above) to operate with the Xpert and BK radio.

## Connection to BK Radio

The 8080-0005-2 can be connected to a BK radio. The connections to the radio are shown below:

RJ-45

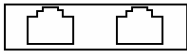

RJ-45 connector	BK Radio Accessories Connector	BK Radio Ext Speaker	Signal direction
1	4 (mic audio)		Audio out of modem
2		Ext Speaker signal	Audio into modem
3	3 (ground)		Ground reference
4-8	No Connect	No Connect	

## Operation with a PC

Configure modem to accept external power since PC does not supply power on pin 9. Connect to a standard serial port on a PC. With the exception of the auto power on mode explained below, the modem will operate as a standard modem.

## Auto power on mode

The modem enters a power-down mode when DTR is low. In this mode, the power is turned off to the modem thus conserving the 120ma that the modem would otherwise use. When a ring is detected on the phone line, the power is automatically turned on to the modem. This power-on sequence takes about 2.5 seconds, at which time the modem will be fully active. Typically, the modem will then answer the phone on the next ring (S0=1) to make a connection with the calling modem.

## Testing/troubleshooting the modem with an Xpert or XLITE

If the modem does not seem to be working with an Xpert, try these following steps. If any tests fail, contact customer service for further help.

### If the modem does not power up

- Check that the jumpers are configured for the correct input power and that the power is making it to the modem.
- To bypass the Xpert and see if the modem powers up, do the following:
  - Configure the internal jumper settings to power from the external power jack/terminal block with +12V.
  - Remove all other connections.
  - Apply +12V power to the modem.
  - Modem should turn on for a few seconds and then power off.
  - Modems with LED installed will light up the LED. For modems without LED verify current draw jumps to about 200 mA and then back down to less than 1 mA.

### If the modem does not answer an incoming call

- Check phone line using a handset. Check all cables between modem and Xpert.
- Via a P.C. and terminal program (HyperTerminal) connected to Xpert com1, issue the command "type autoexec.bat". Verify that remote.exe is being set for a modem connection on the correct com port (I.E a line that states "\windows\remote.exe com1:115200 voice3:115200")
- Make sure "remote.exe" is running by issuing the "Status" command. The Xpert should report that remote is running on COM1 and COMx where x is the port you have connected to the modem.
- Disconnect the modem from the Xpert. Configure jumpers to power modem externally.
- Connect a P.C. with a terminal program to the modem, and apply power via the external power connector.
- Issue an "AT&V" command to the modem. The modem should respond with the current profile and the stored profiles. Verify modem active profile and stored profile is set to: S0=1 E0 Q1 &D0
- Disconnect modem. Configure power jumpers, and reconnect modem to Xpert.
- Dial into the modem either via a phone line or line simulator
- See prompt to login or flash disk if using a terminal program, or see login menu if using Xterm
- If the modem picks up the phone line, but does not speak: Check Dial-in message from Xpert/Xlite

## Compliance Information

Complies with FCC part 68 rules  
FCC REG. NO:3AUSA-33618-M5-E  
REN:0.6B Model: 560-MM-AIR

Industry Canada  
2377 10494

## Specifications/Features

### Features

- RS232 interface, baud rate up to 115,200
- V.90, 56 kbps data receiving
- V.34, 33.6 kbps data sending and receiving
- 14.4 kbps fax, Group 3, Class I and II (not supported by the Xpert)
- Voice playback and record
- DTMF decode
- -40°C to +85°C extended operating temperature
- V.42, MNP 2-4 and 10-EC error correction
- V.42bis, and MNP-5 data compression
- DLG - Digital Line Guard Protection\*

### Agency Approvals

- FCC68 & CS-03 approved
- CSA/UL1950 3<sup>rd</sup> Edition approved (E189947)
- TUV approved (R2072525)

\* DLG - The modem has a built Digital Line Guard Circuit that automatically detects an over current situation on the Tip and Ring pins. It will protect the modem in case it is accidentally connected to a Digital Telephone Line.

### Countries supported by the existing firmware:

Argentina, Australia, Austria, Belgium, Brazil, Canada, China, Denmark, Finland, France, Germany, Greece, Hong Kong, Iceland, India, Ireland, Italy, Japan, Korea, Malaysia, Mexico, Netherlands, Norway, Philippine, Poland, Portugal, Russia, Saudi Arabia, Singapore, South Africa, Spain, Sweden, Switzerland, Taiwan, Thailand, UK, US and TBR21 Generic.

### Ratings @ 25° C

Parameter	Min	Max	Units
Tip / Ring Current Continuous	0	120	mA
Dielectric Withstanding Voltage	-	1650	VRMS
Operating Temperature	-40	+85	oC
Relative Humidity	10	95	o/o
Voltage Requirement	4.75	5.25	V
Power Consumption	720	880	mW
Transmit & Receive Level	-10 (Tx)	-43 (Rx)	dbm