



USING A GILL ULTRASONIC WIND OBSERVER II SENSOR



&

MDS TRANSNET 900

(MDS EL805 Radios)

APPLICATION NOTE

December 2008

Prepared by:
Integrated Systems Division
Copyright© 2008 Sutron Corporation



TABLE OF CONTENTS

PURPOSE 3

PRODUCT OVERVIEW 4

 THE WIND OBSERVER II 4

 MDS TRANSNET 900..... 4

SETUP AND OPERATION 6

 EQUIPMENT 6

 THE MDS TRANSNET 900 SETUP 6

Powering and connecting the MDS Trans NET 900 radio..... 7

Configuring the MDS Trans NET with a PC Terminal..... 7

User commands-Command Line..... 8

 THE WIND OBSERVER II SETUP 9

Connecting the Wind Observer II to a PC..... 9

Configuring the Wind Observer II with a PC Terminal..... 11

Starting Configuration Mode 12

 CONNECTING MDS TRANS NET 900 TO THE WIND OBSERVER II 13

APPENDIX A: 14

 WIRING DIAGRAM..... 14



PURPOSE

The purpose of this application note is to focus on the configuration and connection of the Wind Observer II GILL sensor to MDS Trans NET 900 radios using the RS232 interface.

To obtain information about **General Specifications** of the previous mentioned equipments access the following web sites.

<http://www.microwavedata.com/app/support/technical/manuals/2708D-TransNET-web.pdf>

<http://www.gill.co.uk/data/manuals/WindObserverIIWebManual.pdf>



PRODUCT OVERVIEW

THE WIND OBSERVER II

The Gill Wind Observer II wind sensor is a very robust, lightweight unit with no moving parts, outputting wind speed and direction. The units of wind speed, output rate and formats are all user selectable.

The Wind Observer II can be used in conjunction with a PC, data logger or other device, provided it is compatible with the RS422 output or the analogue outputs. Multiple units can be networked if required.

The Wind Observer II may be configured using Hyper Terminal on a PC.

Features

- ▶ Stainless steel construction
- ▶ Ultrasonic technology
- ▶ Communication via RS 422 interface
- ▶ Analogue outputs, 10Hz outputs
- ▶ Optional de-icing system extending de operational temperature range
- ▶ Wind Observer has a proven record in meteorological, airport, offshore, marine and naval applications
- ▶ Wind Observer has been tested to a number of international standards
- ▶ Maintenance free and requires no calibration on site



MDS TRANSNET 900

The transceiver is a spread spectrum radio designed for license-free operation. These units employ Digital Signal Processing (DSP) technology to provide highly-reliable long-distance communications, even in the presence of weak signals or interference.

DSP technology also makes it possible to obtain information about radio operation and troubleshoot problems, without going to the Remote radio site. Using appropriate software at the Master station, diagnostic data can be obtained on any DSP radio in the system, even while payload data is being transmitted.



Features

- ▶ 902–928 MHz operation using the Trans NET 900
- ▶ User-selectable option to skip sub-bands with constant interference



- ▶ 65,000 available network addresses
- ▶ Network-wide configuration from the Master station eliminates most trips to Remote sites
- ▶ Data transparency ensures compatibility with virtually all asynchronous SCADA system RTUs
- ▶ Peak-hold RSSI averaged over eight hop cycles
- ▶ Operation at up to 115,200 bps continuous data flow
- ▶ Store-and-Forward repeater operation
- ▶ Data latency typically less than 10 ms
- ▶ Same hardware for Master or Remote configuration
- ▶ Supports RS/EIA-232 and RS/EIA-485 user interface
- ▶ Low current consumption; typically less than 3 mA in "sleep" mode



SETUP AND OPERATION

EQUIPMENT

The following equipment is needed to transmit data from a Wind Observer II to a PC using MDS Trans NET 900 radios. Some items are only used for individual configuration of the MDS Trans NET 900 radios

- ▶ MDS Trans NET 900
- ▶ Wind Observer II GILL sensor
- ▶ 12 VDC Power supply
- ▶ NULL Modem adapter
- ▶ RS-422 to RS-232 converter
- ▶ PC running Hyper Terminal for Windows
- ▶ Antenna (900 MHz to 2.4 GHz)
- ▶ RS 232 cable (DB-9)
- ▶ RJ-11 to DB-9 adapter

THE MDS TRANSNET 900 SETUP

In this section we are going to configure the MDS Trans NET 900 radios to transmit data from the Wind Observer II sensor to a PC. We will use a Point-to-Point configuration.

Point-to-Point configuration is a simple arrangement consisting of just two radios (a Master and a Remote). This provides a half-duplex communications link for the transfer of data between two locations.

The following figure shows a typical Point-to-Point Link.



Requirements:

- ▶ MDS Trans NET 900 (2)
- ▶ RJ-11 to DB-9 adapter
- ▶ RS-232 cable
- ▶ Power supply
- ▶ Antenna



- ▶ PC running Hyper Terminal on Windows

The MDS Trans NET 900 radio comes with four LEDs indicators in the front panel. These LEDs indicate the operating status of the MDS Trans NET 900 radio which makes them very helpful when we are testing the MDS Trans NET 900 radio



LED Indicators	
PWR	Continuous - Power is applied to the radio; no problems detected Flashing - (5 times per second) Fault indication Off - Radio is unpowered or in sleep mode
SYNC	Continuous - Radio is receiving/sending synchronization frames On within 10 seconds of power-up under normal conditions
TXD	Transmit data activity on the DB-9 data interface connector. Payload data to connected device
RXD	Receive data activity on the DB-9 data interface connector. Payload data to connected device PC.

POWERING AND CONNECTING THE MDS TRANS NET 900 RADIO

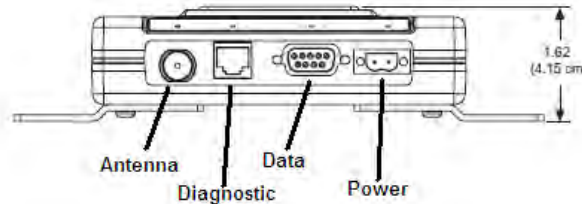

Power: Plug the power supply into the MDS Trans NET radio. A power connector with screw-terminal is provided. The left pin is positive; the right negative

Antenna: Connect a suitable antenna to the TNC connector.

CONFIGURING THE MDS TRANS NET WITH A PC TERMINAL

In order to configure the MDS Trans NET 900 radio, you must use a terminal application such as HyperTerminal in Windows. To open this program, go to: *Start>All programs>Accessories>Communications>Hyper Terminal.*

Specifics “Users Commands” can be used to operate and configure the MDS Trans NET 900 radio. A User commands list is included on the Web site provided at the beginning of this application note. User



commands used in this application notes will be necessary to configure the MDS Trans NET 900 radio for our purpose.

The PC must be connected to the **radio's DIAG connector using an RJ-11 to DB-9 adapter cable (Only for configuration)**.

Once connected, we should be able to communicate to the MDS Trans NET 900 radio via Hyper Terminal. The parameters of communication in the PC for the Port Settings Tap in the Hyper Terminal configuration are:

- ▶ Bits per second: 9600
- ▶ Data Bits: 8
- ▶ Parity: None
- ▶ Stop Bits: 1
- ▶ Handshaking: none.

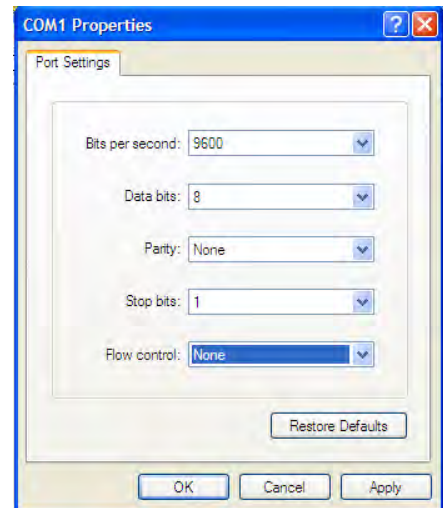

At this point we should be able to communicate with the MDS Trans NET 900 radio. To access to the command interface, press ESC key, followed by one or more ENTER keystrokes, until the ">" prompt is displayed. To verify it, we can type the command "STAT" (then ENTER), this command will show the current alarm status.

NOTE: If the **PWR LED** in the radio is flashing 5 times per second, this means that the MDS Trans NET 900 radio never has been configured before.

USER COMMANDS-COMMAND LINE

The following User commands are required to program the MDS Trans NET 900 radios. Type a <Enter> after each command.

- ▶ Set the Mode using:
 - **MODE M** (Master)
 - **MODE R** (Remote)
 - Only one Master is permitted in a system
- ▶ Set a unique Network address using:
 - **ADDR [1 – 65000]** (use the last four digits of the master's serial number)
 - In the system each radio must have the same Network Address. It could be a number between 1 and 65000



- ▶ Set the Baud rate/data interface parameters using:
 - **BAUD 9600 8N1** (9600 baud, 8 data bits, none (no parity), one stop bit)
 - This command is used to set communications attributes to the RS-232 DATA port. The command has no effect on the RJ-11 DIAG port.

THE WIND OBSERVER II SETUP

In this section we will configure the Wind Observer II. We are going to set the parameters using Hyper Terminal in Windows.

Requirements:

- ▶ Wind Observer II GILL sensor
- ▶ RS-422 to RS-232 converter (ICD 100A)
- ▶ RS-232 (DB-9) cable
- ▶ PC running Hyper Terminal for Windows



CONNECTING THE WIND OBSERVER II TO A PC

In order to configure the WOII we must use a RS-232 interface to connect the Wind Observer II to a PC. The Wind Observer II has been designed with a RS-422 digital output, for this reason we use a RS-422 to RS-232 converter (ICD 100A). A complete wiring diagram is provided in the Appendix A.

The RS-422 to RS-232 converter (ICD 100A) requires a simple configuration that is done selecting the correct combination of dipswitches. These dipswitches are located in one side of the RS-422 to RS-232 converter.

The following figure shows the combination of dipswitches for our purpose.

S1	S2	S3	S4	S5	S6	S7	S8
Off	Off	Off	Off	Off	On	Off	Off

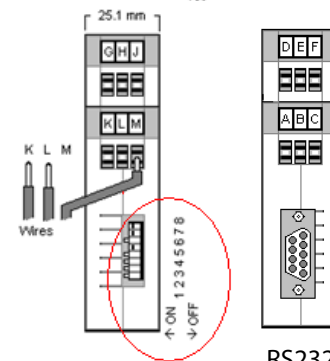

The following figure shows the WOII connected to a PC using

RS232 interface.

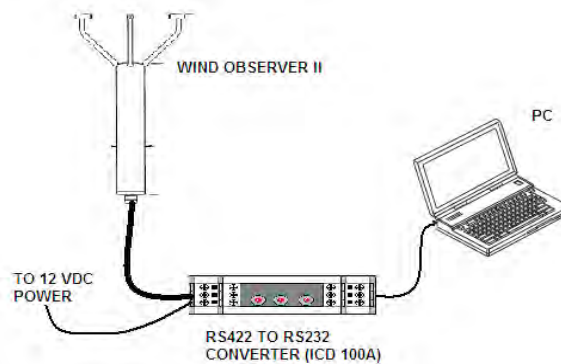



CONFIGURING THE WIND OBSERVER II WITH A PC TERMINAL

In order to configure the Wind Observer II, you must use a terminal application such as HyperTerminal in Windows. To open this program, go to: *Start>All programs>Accessories>Communications>Hyper Terminal.*

Specifics “*Commands*” can be used to operate and configure the Wind Observer II. A User commands list is included on the Web site provided at the beginning of this application note. User commands used in this application notes will be necessary to configure the Wind Observer II for our purpose.

Once connected, we should be able to communicate to the Wind Observer II via Hyper Terminal. The parameters of communication in the PC for the Port Settings Tap in the Hyper Terminal configuration are:

- ▶ Bits per second: 9600
- ▶ Data Bits: 8
- ▶ Parity: None
- ▶ Stop Bits: 1
- ▶ Handshaking: none.

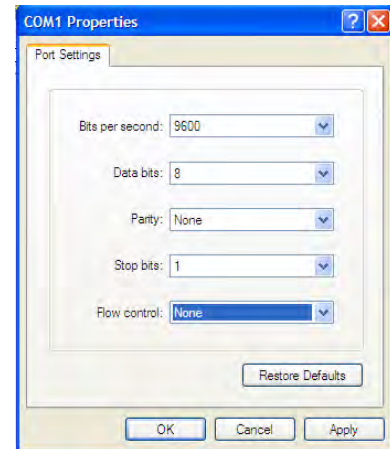

At this point we should be able to communicate with the Wind Observer II. To access to the command interface, press ENTER key, until the Wind Observer II respond with wind measurements. The Wind Observer II is set to MEASUREMENT MODE by default.



STARTING CONFIGURATION MODE

After we establish connection with the Wind Observer II we can start the CONFIGURATION MODE as follows:

Press **ENTER** key after each command

Enter ****** to start **CONFIGURATION MODE**.

- D3** to see current setting
- A0** Speed of sound and temperature disable
- B3** 9600 Baud rate
- C1**
- E1** Full Duplex
- F1** 8 bits, no parity, 1 stop bit
- G0000** Average period in seconds
- J1** Enable analogue power up test
- K1** NMEA string "IIMWV"
- L1** ASCII Message terminator CR LF
- M2** ASCII Polar Continuous
- NB** B is the unit identifier, can be any letter from B to Z
- O1** Message Format = Comma Separated Variable (CSV)
- P1** Output rate P1= 1 per second
- T1** Voltage or current output (0 to 5V, or ± 2.5 V)
- U1** Units in m/s
- V1** Disable vertical output padding
- X1** Aligns U axis with North/South axis
- Y1** Channel 3 Output Y1=status
- Z1** Scaling Z1= ± 10
- D3** To see current settings
- Q** Return to MEASUREMENT MODE



CONNECTING MDS TRANS NET 900 TO THE WIND OBSERVER II

After the MDS Trans NET 900 radio and the WIND OBSERVER II have been configured, we use the RS-232 (DATA Port) interface to connect the MDS Trans NET 900 radio to the Wind Observer II using a NULL MODEM CONNECTOR.

The following figure shows a complete system. In one side we have the MASTER radio with the PC and in the other side the REMOTE radio with the Wind Observer II.

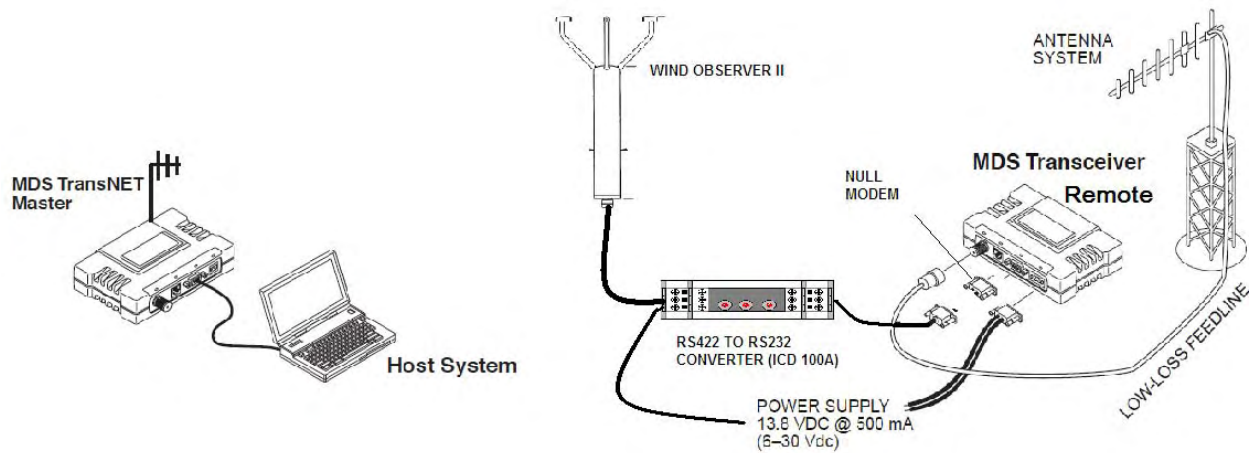



APPENDIX A:

WIRING DIAGRAM

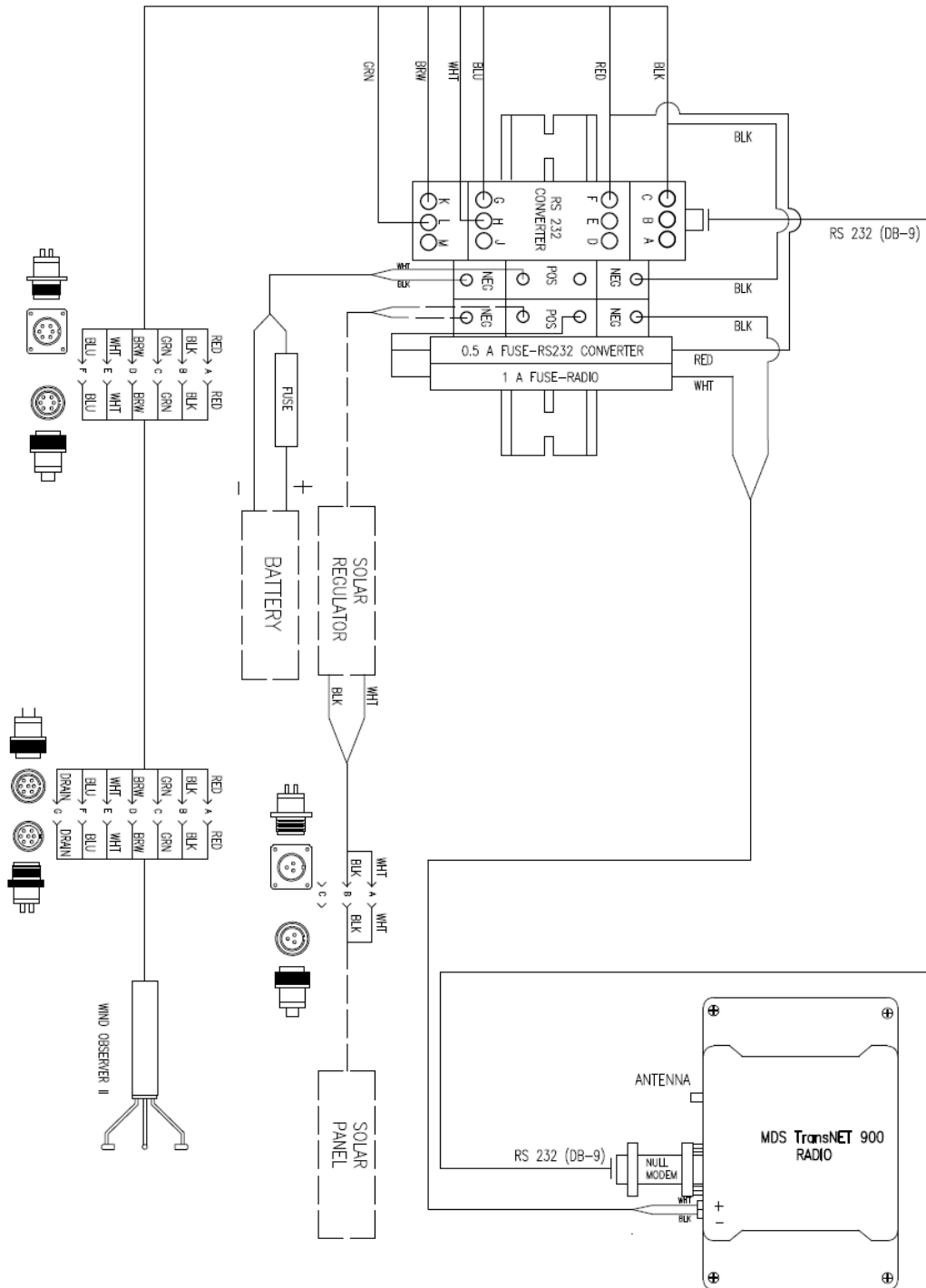



APPLICATION NOTE

Using the Gill Wind Observer II with MDS TransNET 900 Radio
