

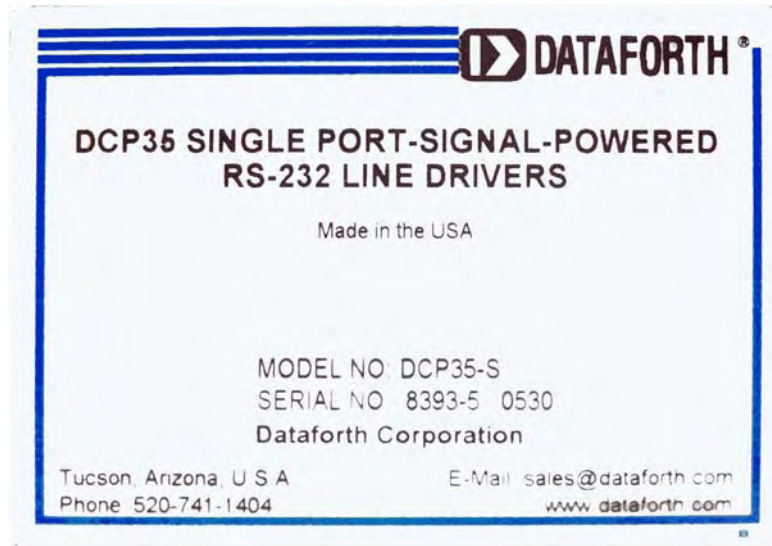

# APPLICATION NOTE

DataForth DCP35 Single Port Signal-Powered RS-232 Line Drivers- 19200 BPS Wire



**[DataForth]  
[DCP35 RS-232 line driver set] [www.dataforth.com]  
APPLICATION NOTE**



**Prepared by:  
Integrated Systems Division  
The Sutron Corporation  
21300 Ridgetop Circle  
Sterling, VA 20166**



# APPLICATION NOTE

DataForth DCP35 Single Port Signal-Powered RS-232 Line Drivers- 19200 BPS Wire

---

## TABLE OF CONTENTS

1.	INTRODUCTION .....	1
2.	INSTALL THE PC END .....	2
3.	INSTALL THE RADIO END .....	3
4.	CONNECT THE 4 WIRES TO THE UNITS .....	4
5.	INTERNAL WIRING DETAILS AND TESTING .....	5
6.	DCP35 TECHNICAL SPECIFICATIONS .....	6



## 1. Introduction

This app note explains how to connect a matched set of DataForth DCP35 RS-232 line drivers to transport serial data up 19200 bps over low cost 4 wire telco wire. These drivers can be used to extend the distance between a Sutron XConnect computer using a COM port to send data and an external radio such as an Integra radio unit. This is a perfect application of these drivers as it allows a close proximity of the radio to the antenna without regard to where the PC is to maximize TX power out of the radio.

### Features:

- Self powered from the DTR signal line presented by the PC DB9 connector
- Can be mounted on the wall next to the radio if needed
- Separation distance up to 8 tenths mile using low cost (4) AWG24 solid wire
- Use standard RadioShack 9 pin serial M-F cables to connect to the associated PC and radio units
- Bit rates up 19200 bps (per spec) although the tested units worked fine at 38400 bps using Hyperterminal



## 2. Install the PC end

Identify a location in close proximity of the PC to mount one unit of the DCP35S line drivers.

The DB9 female connector unit part number DCP35S is what goes here. Figure 1 shows what this unit will look like. Use a standard DB9 M-F cable to connect the PC DB9 COM port connector to the DCP35 unit. Make sure the DCP35 is switch selected for DCE at this time.



Run a 4 wire line from this unit to the other DCP35P unit.



### 3. Install the radio end

Identify a location in close proximity of the radio to mount the other unit of the DCP35P line drivers.

The DB9 male connector unit part number DCP35P is what goes here. Figure 2 shows what this unit will look like. Use a standard DB9 M-F cable to connect the radio COM port connector to the DCP35 unit. Make sure the DCP35 is switch selected for DTE at this time.



## 4. Connect the 4 wires to the units

Using the 4 wires, connect the units as shown in figure 3. In the drawing below the PC end is on the left(explained as 1/2 of DCP35)

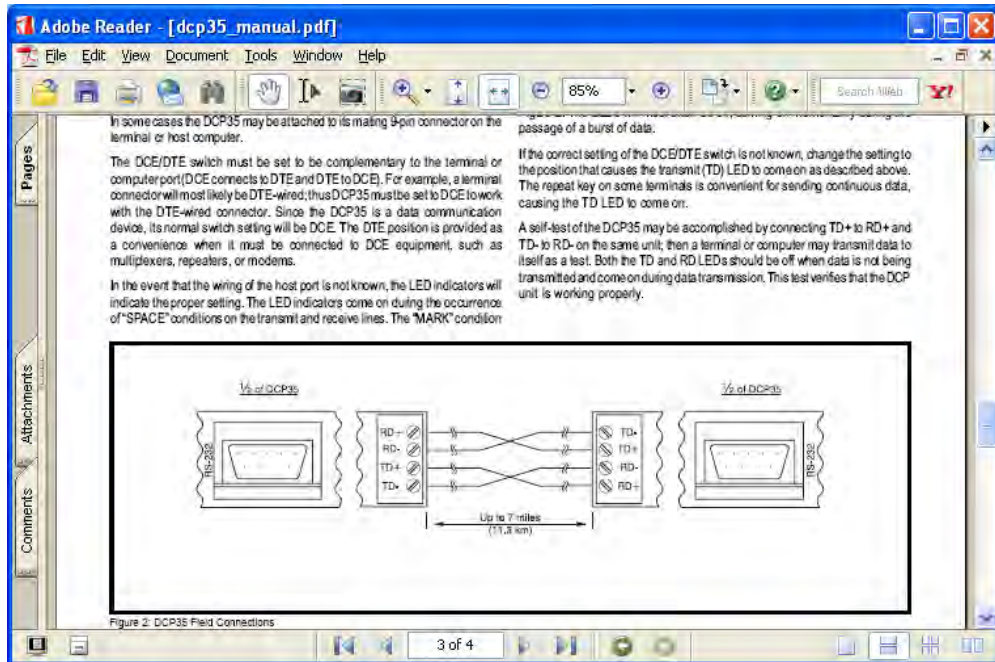

Figure 3 connecting the 4 wires of each unit

The exact wiring with the units tested is shown in figure 4.

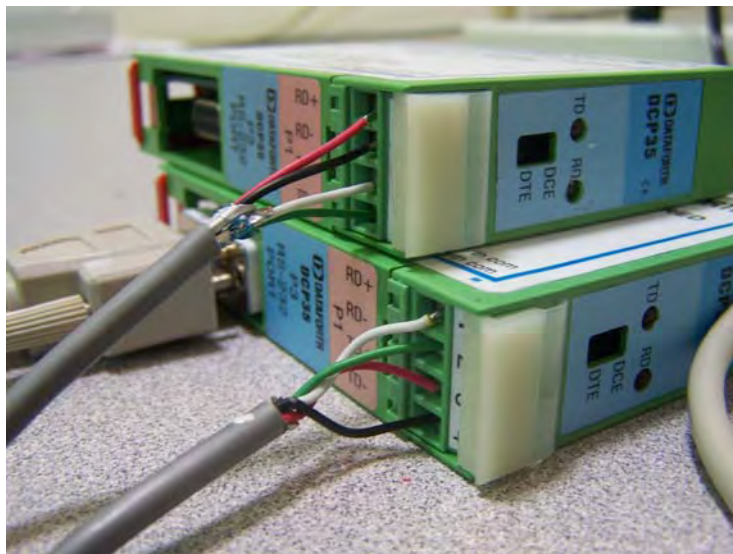

Figure 4 wiring from unit to unit shown here

Again, the PC end is on top(red wires on the top as shown).

## 5. Internal wiring details and testing

Here are wiring details of the how the internal connections are done

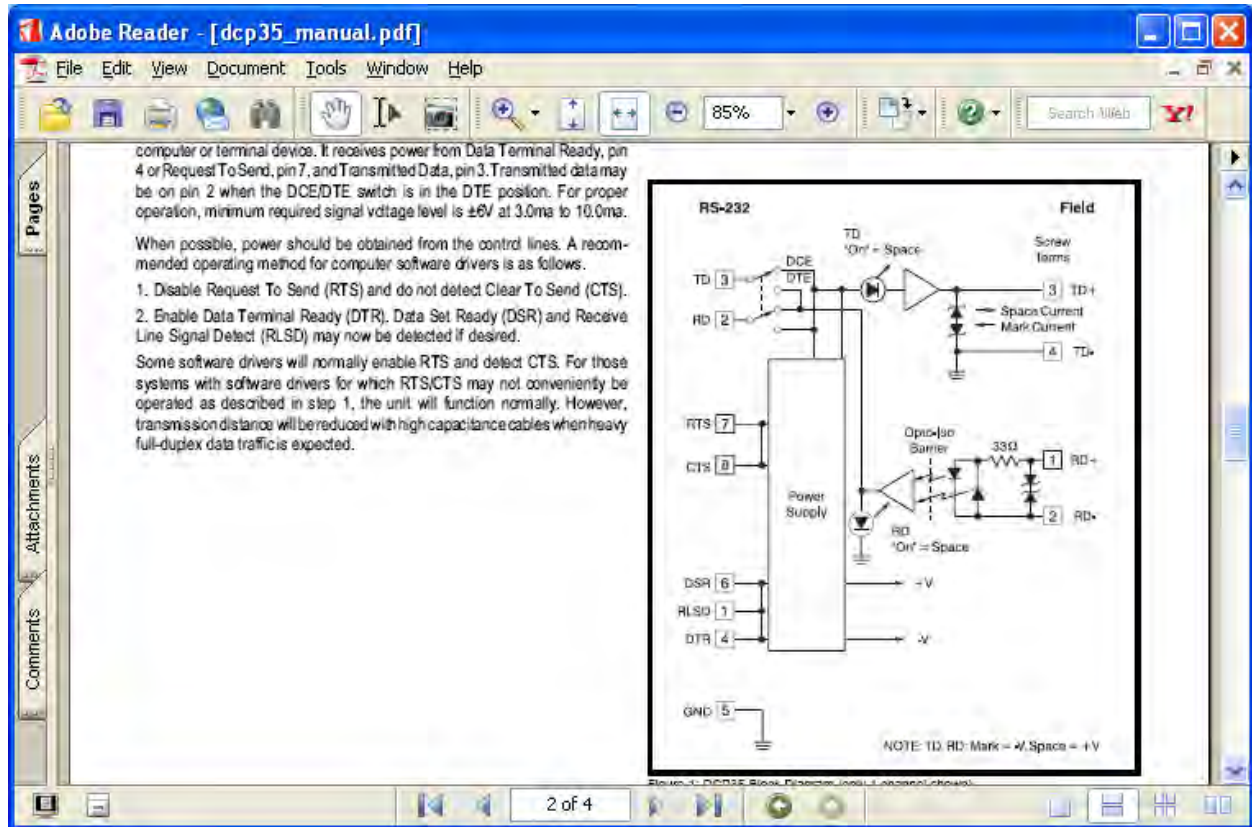

Figure 5 internal details

The units tested (S/N 8393-5 for DCP35S and 8749-2 for DCP35P) operated fine with 38400 8N1 settings in Hyperterminal. This is beyond spec (19200 max) as a way of “pushing” the units past their limits to see what happens.

Bit rates tested: 2400, 9600, 19200 and 38400 bps with 8N1 settings.

Modem signal state: DTR/RTS/DCD/DSR were all at +6V meaning Hyperterminal was set for hardware handshake here. This is needed to have the internal voltage levels of the line drivers setup. A breakout box was used to verify this. Pin 7 is voltage common. Keep in mind that DTR comes from the PC and DSR comes from the radio along with DCD assuming the carrier is ON.

One observation is that it takes 1-3 minutes to establish the internal voltages of the units to send data with NO errors. This was the case for bit rates from 2400 to 38400 bps, it didn’t seem to matter. This is to be expected as the internal operating voltage is derived from the DTR signal coming in. This was observed from either end by disconnecting the cable on the PC and re-connecting. It took several minutes to get good data in/out of the units

## 6. DCP35 Technical Specifications

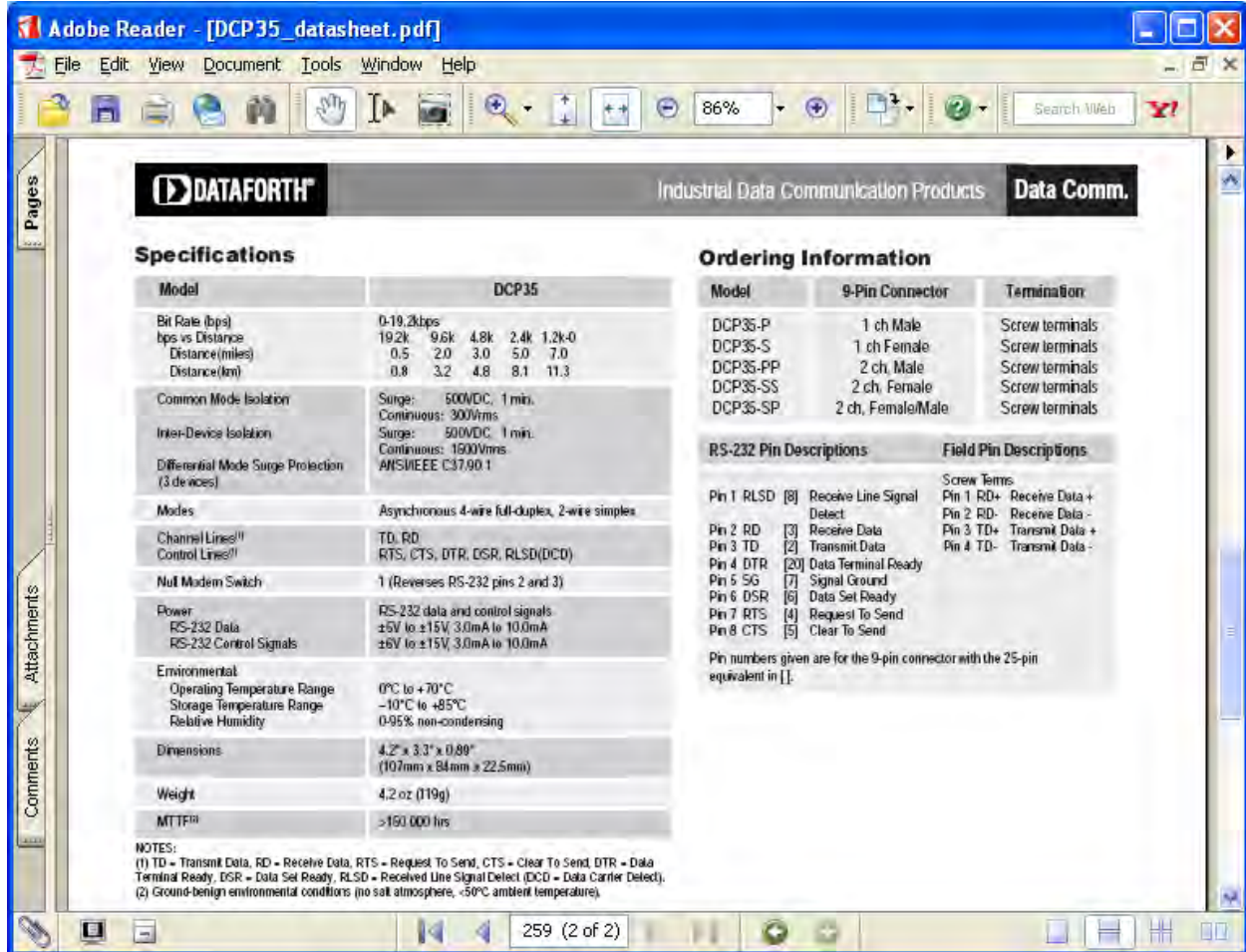

**DATAFORTH** Industrial Data Communication Products **Data Comm.**

### Specifications

Model	DCP35
Bit Rate (bps)	0-19.2kbps
bps vs Distance	19.2k 9.6k 4.8k 2.4k 1.2k-0
Distance (miles)	0.5 2.0 3.0 5.0 7.0
Distance (km)	0.8 3.2 4.8 8.1 11.3
Common Mode Isolation	Surge: 500VDC, 1 min. Continuous: 300Vrms
Inter-Device Isolation	Surge: 500VDC, 1 min. Continuous: 150Vrms
Differential Mode Surge Protection (3 devices)	ANSI/IEEE C37.90.1
Modes	Asynchronous 4-wire full-duplex, 2-wire simplex
Channel Lines <sup>(1)</sup> Control Lines <sup>(1)</sup>	TD, RD RTS, CTS, DTR, DSR, RLSD(DCD)
Null Modem Switch	1 (Reverses RS-232 pins 2 and 3)
Power	RS-232 data and control signals ±5V to ±15V, 3.0mA to 10.0mA
Environmental	Operating Temperature Range Storage Temperature Range Relative Humidity
	0°C to +70°C -10°C to +85°C 0-95% non-condensing
Dimensions	4.2" x 3.3" x 0.89" (107mm x 84mm x 22.5mm)
Weight	4.2 oz (119g)
MTTF <sup>(2)</sup>	>150,000 hrs

### Ordering Information

Model	9-Pin Connector	Termination
DCP35-P	1 ch Male	Screw terminals
DCP35-S	1 ch Female	Screw terminals
DCP35-PP	2 ch, Male	Screw terminals
DCP35-SS	2 ch, Female	Screw terminals
DCP35-SP	2 ch, Female/Male	Screw terminals

### RS-232 Pin Descriptions

Pin	Signal	Description
Pin 1	RLSD [8]	Receive Line Signal Detect
Pin 2	RD [3]	Receive Data
Pin 3	TD [2]	Transmit Data
Pin 4	DTR [20]	Data Terminal Ready
Pin 5	SG [7]	Signal Ground
Pin 6	DSR [6]	Data Set Ready
Pin 7	RTS [4]	Request To Send
Pin 8	CTS [5]	Clear To Send

### Field Pin Descriptions

Pin	Signal	Description
Pin 1	RD+	Receive Data +
Pin 2	RD-	Receive Data -
Pin 3	TD+	Transmit Data +
Pin 4	TD-	Transmit Data -

Pin numbers given are for the 9-pin connector with the 25-pin equivalent in [].

**NOTES:**  
 (1) TD - Transmit Data, RD - Receive Data, RTS - Request To Send, CTS - Clear To Send, DTR - Data Terminal Ready, DSR - Data Set Ready, RLSD - Received Line Signal Detect, DCD - Data Carrier Detect.  
 (2) Ground-benign environmental conditions (no salt atmosphere, -50°C ambient temperature).

Figure 6 table from manual describing specs