

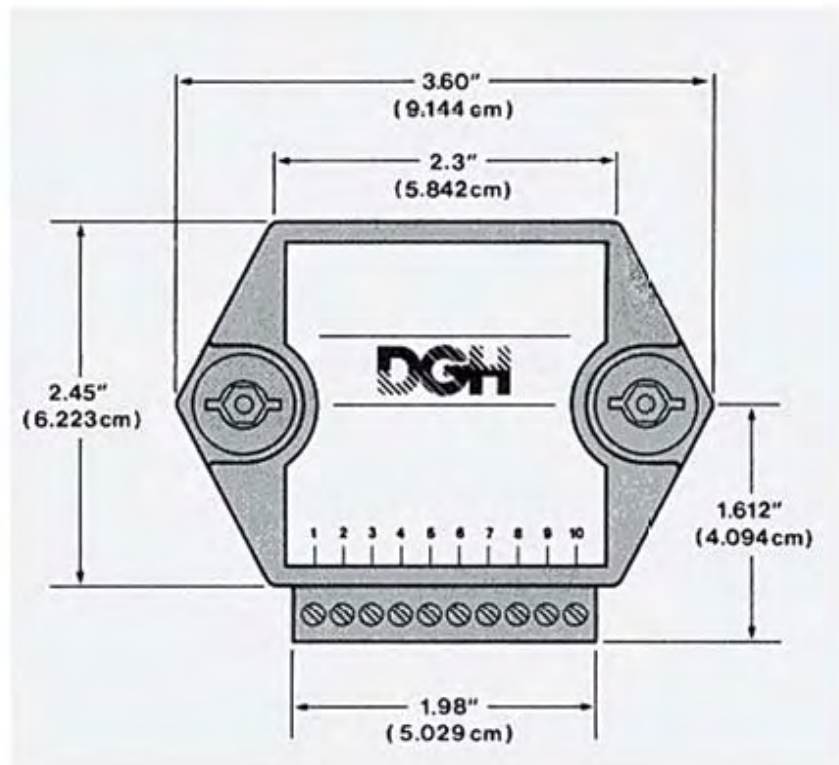

Use of DGH Output Module with Xlite/Xpert and DGH.sll



Prepared by:
R&D
April, 2003



DGH Analog Output (DGH)

Inputs

Data

Outputs

Data

Wiring

*Set com port to provide +12V out. Check current output limits from logger manual first, if pin 9 cannot supply required current, connect GND and +VS directly to +12V power source of data logger.

DGH	Com Port Pins (Com ports 2 and above)	Optionally through 6461-1239 RS-232 term board (Connector J2)
Transmit	2	2
Receive	3	3
GND	5*	5*
+VS	9*	6*

Description

This block performs a calculation on its input and sends the computed value in a string through a com port. The calculation is as follows:

$$Y = ((\text{deltaOutput}/\text{deltaInput}) * (\text{Data} - \text{InputLow})) + \text{OutputLow}$$

Where deltaOutput is OutputHi – OutputLow and deltaInput is InputHi – InputLow.

The calculation allows you to scale input data to a range specific to the DGH module.

For example, if the input data were wired to an Air Temp block with a range of -40 to +100 C, the setup would be as follows:

<p>For a 4-20ma module: INPUT HIGH: 100 INPUT LOW: -40 OUTPUT HIGH: 20 OUTPUT LOW: 4</p>
--

<p>For a 0-5000mV module (0-5V): INPUT HIGH: 100 INPUT LOW: -40 OUTPUT HIGH: 5000 OUTPUT LOW: 0</p>

You can even limit the output such that you direct a 4-20mA module to only generate 10-20mA if needed.

This block will work on any DGH output module that responds to the following output string:

\$1AO+0yyyy.yy followed by a CR



Where yyyy.yy is the Y value computed above, prefaced with a zero if less than 10. If the DGH module does not reply with a * within 1 second, a warning is issued.

NOTE: Baud rate, and any other DGH setup, must be done before connecting to the data logger. Defaults of DGH at the time of print of this App note were for 300 baud and to not echo characters, this will allow one module to be connected to each com port with no further configurations needed.

Setting up a "Daisy-chain network" is possible, simply configure the network according to the DGH user manual and connect them to one com port. When setting up the blocks, set all of them to the same com port, with the appropriate addresses selected.

