



**TELULAR SX4E PHONECELL
WITH THE
8210 SPEECH MODEM**

APPLICATION NOTE

September 2004



**Integrated Systems Division
The Sutron Corporation
21300 Ridgetop Circle
Sterling, VA 20166**

Copyright© 2004 Sutron Corporation

TABLE OF CONTENTS

1. Overview	1
2. Equipment and Options.....	2
3. Equipment Connections and Specifications	2
3.1 Equipment Specifications.....	3
3.1.1 CELLULAR MODEM FEATURES	3
3.2.1 8210 Speech Modem Features.....	3
4. Cellular Modem Activation	5
5. Speech Modem Setup.....	6
6. 8210 Data Logger with Speech Modem Setup.....	7
6.1 Speech Modem Menu Setup.....	7
6.2 Sample Sensor Setup	10
7. Troubleshooting	11

1. Overview

The Telular PhoneCell SX4e is a tri-mode (TDMA/PCS/AMPS) cellular modem capable of supporting Voice, FAX and Data operation. Voice operation is supported in all modes.

This makes the Telular PhoneCell SX4e best suited for applications requiring voice reports.

The Telular PhoneCell SX4e is a fixed wireless terminal (FWT). These FWT devices are based on Telular's proprietary RJ-11 to cellular interface technologies. This allows connection to the Sutron 8210 Speech Modem using a standard RJ-11 cable connection.

Data operations with the Phonecell are dependent on several factors including your local cellular service provider. Because most TDMA and PCS networks do not support digital fax and data services, AMPS 800 MHz networks or AMPS 800 MHz channels on TDMA 800 MHz networks are used for fax and data services. Contact your local cellular dealer or service provider to determine the availability of an AMPS analog network. Other cellular products are best suited for data only applications.

The Sutron 8210 Speech Modem will allow voice communication with the 8210 Data Loggers. User's may dial in and obtain real-time readings via voice reports. Voice reports of alarm conditions defined by the user can be transmitted to up to three different phone numbers by the 8210 Speech Modem dialing out using the SX4e Phonecell FWT.

The following sections present:

- ▶ The required equipment and options
- ▶ Equipment cable connections and equipment specifications
- ▶ Instructions for setting up cellular service and the SX4e FWT
- ▶ Instructions for setting up the 8210 Speech Modem

Complete instructions for programming the 8210 can be found in the 8210 Users Manual. A copy this manual is available at:

www.sutron.com/DownloadsUpdates/8200_8210Manuals.ZIP

2. Equipment and Options

The application requires the following equipment:

	Part Number	Description
1	8210-3014-1A	8210 Data Logger with Speech Modem
2	8111-7000-1	Phonecell SX4e FWT with RJ-11, serial cables, battery power cable

PHONECELL® is a register trade mark of the Telular Corporation.

The Telular SX4e is supply with an eight (8) inch ONMI antenna intended for interior mounting. The antenna input connection of the SX4e is a TNC female connection. This antenna is suited for use in areas with strong cellular service signal. The following antenna options are available:

8111-1168-1 Antenna, YAGI, 800MHz, 6db w/20ft RF cable

8111-1168-2 Antenna, ONMI, Dual Band 800-1900 MHz, Xdb w/20ft RF cable

8111-1168-3 Antenna, YAGI, 1900MHz, 6db w/20ft RF cable

Each includes a coaxial surge protector and 3ft jumper cable to interface from the protector to the SX4e FWT.

3. Equipment Connections and Specifications

The equipment configuration consists of an 8210-3014-1A Data Logger with Speech Modem option and a SX4e cellular FWT.

The cellular modem transceiver will be connected to the 8210 Speech Modem using an RJ-11 connection. The cellular modem has an RJ-45 receptacle, connect a cable from this port to the RJ-11 receptacle of the Sutron RJ-11 module that comes with the 8210 Speech Modem. This RJ-11 module connects to the Phone T and R inputs in the 8210 terminal block.

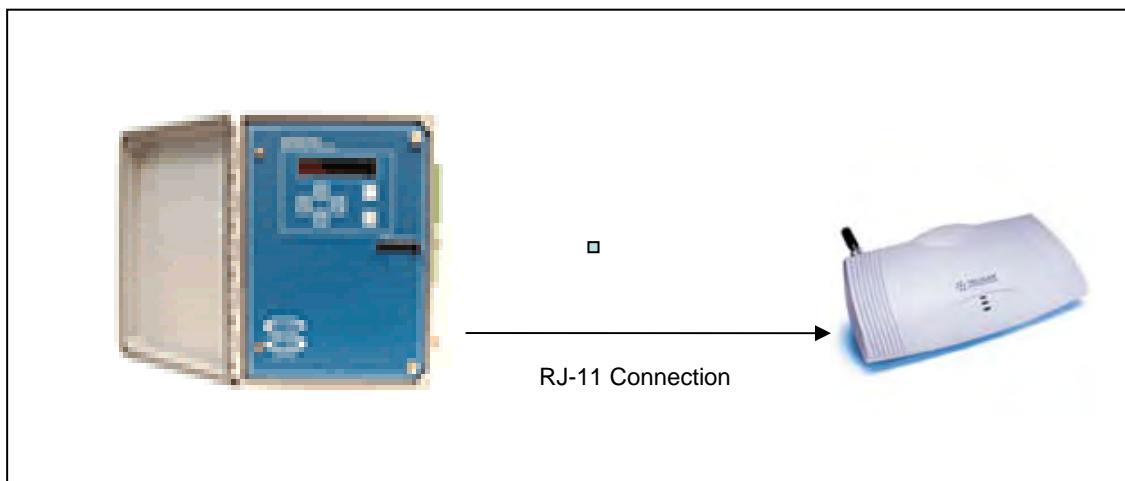

Figure 1 8210 connects to the SX4e FWT via a standard RJ-11 phone cable.

3.1 Equipment Specifications

3.1.1 CELLULAR MODEM FEATURES

- ▶ Exceptional voice quality with echo cancellation and digital voice/data privacy
- ▶ DTMF and pulse-dial capability
- ▶ External linear power supply
- ▶ Built-in signal strength indication and self monitoring capabilities for user diagnostics
- ▶ Easily programmed using ordinary telephone

3.1.1.1 Specifications

Air Interface Standard

- ▶ GSM
- ▶ TDMA
- ▶ PCS
- ▶ AMPS (ANALOG)

Transmit Power

- ▶ Maximum 600mW

Operating Voltage

- ▶ 12VDC (11.5 to 26 VDC)

Environment

- ▶ Operating temperature range: -10C to +50C
- ▶ Storage Temperature Range: -25C to +65C
- ▶ Humidity 5% to 95%

LED Indicators

- ▶ Power Status
- ▶ Cellular Status
- ▶ FWT Status

Connectors

- ▶ RJ-45 interface jack for voice (Accepts RJ-11 phone line connector)

3.2.1 8210 Speech Modem Features

- ▶ Provides voice report of sensor values
- ▶ DTMF (Dual Tone Multi-Frequency) Decode
- ▶ Speech menu options using DTMF signals

- ▶ -40C to +85C extended operating temperature

3.2.1.1 Specifications

- ▶ **Operating Temperature** -40°C to +60°C
- ▶ **Electronics** Protected to 3000 Volt (peak), 500 Joule transient phone line surges from tip to ring, tip to ground, and ring to ground. Low power standby mode. Receiver sensitivity-45dBm. Receiver dynamic range 36dBm (-9dBm to -45dBm)
- ▶ **Standard Interface** Telephone 2 wire to RJ-11 modular jack
- ▶ **Mode Capability** Full duplex over public switched telephone network (PSTN). Bell 212A (1200 pbs) and Bell 103 (300 bps). CCITT V.22 (1200 bps) and V.21 (300 bps)
- ▶ **Answer Mode** Ring detect. Auto-baud rate detection. 2225 Hz Answerback Tone. 30 second timeout if baud rate training sequence not complete
- ▶ **On-Hook/Off-Hook** On-hook call termination after autoanswer or auto-dial timeout
- ▶ **With Call Termination** 30 seconds (programmable) of data inactivity. System reset. Power-up initialization.
- ▶ **Applicable Standards** Phone Line Interface meets or exceeds the following standards:
 - U.S.Federal Communications
 - Commission (FCC). Rules and
 - Regulations Part 68
 - Canadian Department of
 - Communications - Standard CS-03.
 - Electronic Industries Assoc. (EIA) Standard RS-496

4. Cellular Modem Activation

Selection of a cellular service provider involves several considerations including: signal strength at the remote site, system type (TDMA\PCS\AMPS), and service plan cost. Most established services started with AMPS and are required to maintain this service. Digital data service may be available and may be at a lower cost. Consult your service providers in the area of the station to determine the best selection. Once a service provider has been selected and service has been initiated, the SX4e needs to be programmed for the system.

The SX4e is programmed with an ordinary tone-dial (DTMF) telephone, which is sometimes referred to as POTS (Plain Old Telephone Service) phone. The following steps provide a typical programming setup. Consult the Phonecell SX4e User Manual for the detailed programming instructions. Except for the Mobile Identification Number (MIN) discussed below, the factory defaults will work in most cases. Be certain to review the programming steps given below with your service provider or have your service provider program the Phonecell.

The exact programming may vary from model to model, refer to Telular Phonecell User Manual sent with the unit for final instructions.

Before you begin programming, connect the antenna, plug in the power, and connect a tone-dial (DTMF) telephone.

1) Pick up the POTS telephone handset and listen for a tone (either a steady dial tone or a beeping no-service tone).

2) **Press: # * 0 * 1 2 3 4 4 3 2 1 #**

The tone will change to a different, steady "Programming" tone and the bottom LED indicator on the Phonecell will blink alternately RED and GREEN to indicate that you're in programming mode. You now have two minutes to start the programming steps.

3) **Press: # * 1 * <MIN> #**

This key sequence is used to enter your 10-digit telephone number (**Mobile Identification Number, or MIN**). If you enter the number incorrectly, you'll hear 3 short tones followed by the programming tone. If correct, you'll hear the programming tone again. If the MIN phone number value is not 10 digits, it is considered invalid and the FWT will not update or store this value; the currently stored value will remain.

Note – With the instigation of phone number portability, user phone number may be different from the MIN. Make certain the service provider gives you both the user phone number and the MIN.

4) **Press: # * 5 * <SID> #**

This key sequence is used to enter the 1- to 5-digit **System Identifier, or SID**. This information identifies your cellular service company. If you enter the SID incorrectly, you'll hear three short tones followed by the programming tone; if correct, you'll hear the programming tone again. If the SID value is not in the range of 0 to 32,767, it is considered invalid. The factory default is **69**.

5) **Press: # * 4 * <paging channel> #**

This key sequence is used to set up your 1- to 4-digit **initial paging channel**. When you turn on your Phonecell, this channel helps the service provider find you-and viceversa. If the paging channel is not in the range of 1 to 1023, it is considered invalid.

NOTE: channels 800 to 990 are invalid. The factory default channel setting is **333**.

6) **Press: # * 7 * <band order> #**

This key sequence is used to enter the **band order**. The band order value is a series of digits between 1 and 2 that must be at least 1 digit and not more than 2 digits long. The following table describes the relationship between the band order digits and EIA/TIA-136 system/band assignment:

Band Order Digits EIA/TIA-136

1 System A (800 MHz)

2 System B (800 MHz)

3 Band A (1900 MHz)

4 Band B (1900 MHz)

5 Band C (1900 MHz)

6 Band D (1900 MHz)

7 Band E (1900 MHz)

8 Band F (1900 MHz)

If the band order values are not in the range of 1 to 8, or there are less than 1 or more than 8 digits, the entry is considered invalid. The factory default is **3 4 1 2 5 6 7 8**.

- 7) Hang up the phone. The flashing LED indicator will become solid GREEN.

Phone Number Setup is complete.

5. Speech Modem Setup

The 8210-3014-1A is shipped from the factory with the Speech Modem installed and the 8210 configured as a Speech Modem unit. Users can purchase Speech Modem modules to be added in the field. The part number for this module is 8200-3000-3 and includes:

- ▶ Speech Modem Module
- ▶ Interface Cable
- ▶ RJ-11 receptacle with 6 inch phone cable
- ▶ Mounting hardware (screws and washers)

The typical installation would place the Speech Modem module in the upper option location of the 8210. The interface cable would be connected to the cable header labeled J5 (nearest the edge of the 8210 Microprocessor module). When connected to the J5 header, the S1 DIP switches on the 8210 Microprocessor board need to be set as:

- ▶ SW3 CLOSED
- ▶ SW4 OPEN

(Switch settings the 8210 are described in Chapter 11 of the *8210 Operations Manual*.)

6. 8210 Data Logger with Speech Modem Setup

This section presents the setup steps that enable the 8210 to use the Speech Modem. An example setup of one sensor input configured to use the Speech Modem is included.

(Complete details for setting up the Speech Modem are presented in the Modem Setup section of Chapter 4 of the *8210 Operators Manual*.)

6.1 SPEECH MODEM MENU SETUP

The 8210 unit requires the following minimum setup to use the Speech Modem:

- ▶ Configure the Speech Modem Menu
- ▶ Configure a sensor in the ALARMS Menu

The Speech Modem will also operate in the data mode when used with the Phonecell unit and AMPS service is available. If data access is planned it is highly recommended to do the following additional setup steps:

- ▶ Set a phone password in the Speech Modem Menu
- ▶ Set the Enter Key Required mode to **ON** in the EEROM Menu

Failure to do this last step can lead to loss of the 8210 setup configuration due to a noisy or poor quality phone connect.

6.1.1 Configuring the Speech Modem Menu

The 8210 Main Menu is displayed below. Enter M to go to the Speech Modem Setup Menu.

```

SUTRON Corp 8210A SR48
Peer-to-Peer RTU Software

MAIN MENU
N - Unit Name          PHONECEL
D - Set Date           09/09/2004
T - Set Time           17:37:58
R - Recording Status   ON
C - Clear Alarm        NORMAL
V - View Sensor Data
S - System Setup Options
U - Upload/Download Data
E - EEROM Setup Options
P - Protocol Setup Options
M - Speech Modem Setup
G - GOES Radio Setup
I - Inspect System
A - Application Menu
B - AX25 Alarms Setup Menu
X - Exit
Choose: _

```

Figure 2 8210 Main Menu

The Speech Modem Menu is shown below. A minimum setup would include setting:

- ▶ the Answer Mode (Voice, Voice & Data, Data & Voice)
- ▶ the number of rings before answering (default, 1)
- ▶ Dial-In message

```

Modem Setup Menu
D - Dial-Out Enable    OFF
A - Answer Mode        VOICE & DATA
N - Number of Rings    1
P - Phone Password     A
I - Dial-In Message    Liv
O - Dial-Out Message
1 - Phone #1
2 - Phone #2
3 - Phone #3
R - Redial Delay       00:10:00
Choose: _

```

Figure 3 Speech Modem Menu

The Dial-In message shown above is one of the “canned” reports that will speak the name and value of the last measured value of each sensor enabled for “current data” (see Section 6.2 below).

Users can create a message using a vocabulary string. An example shown below uses a Speech Modem string to speak the following message:

Welcome	to	the	Sutron	82	10
182	2	:173	:170	82	10

```

Speech Modem Menu
D - Dial-Out Enable          OFF
A - Answer Mode             VOICE & DATA
N - Number of Rings         1
P - Phone Password
I - Dial-In Message         @182 2 :173:170 82 10n34:
O - Dial-Out Message
1 - Phone #1
2 - Phone #2
3 - Phone #3
R - Redial Delay            00:10:00
Choose:
DialIn: @182 2 :173:170 82 10n34:127r34u34
    
```

Figure 4 Example Speech Modem Vocabulary String

The 8210 can be setup to Dial-Out and make voice reports of alarm conditions. This would be enabled by setting the Dial-Out Enable to **ON**, at least one phone number, and establishing a Dial-out Message string.

(Complete details for using the 8210 vocabulary are presented in the Modem Setup section of Chapter 4 of the *8210 Operators Manual*.)

6.2 SAMPLE SENSOR SETUP

The last step in this example setup shows how a sensor is set to enable "Current Data" to be included in the canned "Liv" report. This is done using the Alarm Sensor Options Menu. This Menu is accessed from the System Setup Menu.

```

[ ALARM SENSOR OPTIONS ]
Choose [U]p [D]own [E] [G] [C] [T] [1] [2] [3] [H] [L] [R] [B] [P] [S]:

Active Sensors
> Battery
  BARO

Alarm Options
  E - Enable           ON
  G - Groups           0000
  C - Control          OFF
  T - Trend            OFF
  1 - High Alarm       OFF
  2 - Low Alarm        OFF
  3 - ROC Alarm        OFF

Alarm Limits
  H - High Limit       0.000
  L - Low Limit        0.000
  R - ROC Level        0.000
  B - DeadBand         0.000

Alarm Phrases
  P - Prefix (Name)    67
  S - Suffix (Units)   177

```

Figure 5 Alarm Sensor Option Menu

The figure above shows that the sensor named Battery has Alarm Options Enable **ON**, with the Alarm Phases set to 67 (battery) and 177, (volts). These settings will cause the Liv report to state:

" Battery is 12.52 volts."

Other settings in the Alarm Sensor Option menu can be used to set high, low, or ROC (rate-of-change) alarms. These settings could be used to have the Speech Modem dial out to up to three phone numbers and announce alarm conditions with current sensor values.

(Complete details for using the 8210 Alarm Sensor Option are presented in the System Setup\Alarm Options section of Chapter 4 of the *8210 Operators Manual*.)

7. Troubleshooting

Possible Problem	Checkpoints/Solutions
The modem answers, but the voice is of poor quality(noisy)	Check cell phone coverage in the area. The cell phone has 3 LEDS, they should all be green.
The modem does not pick up, you obtain a dead signal.	Check if the cell modem has 12V.
	Check external battery, voltage should be around 12VDC.
I can obtain voice messages from the modem, but no data	Contact local cellular provider to see if this feature is available